

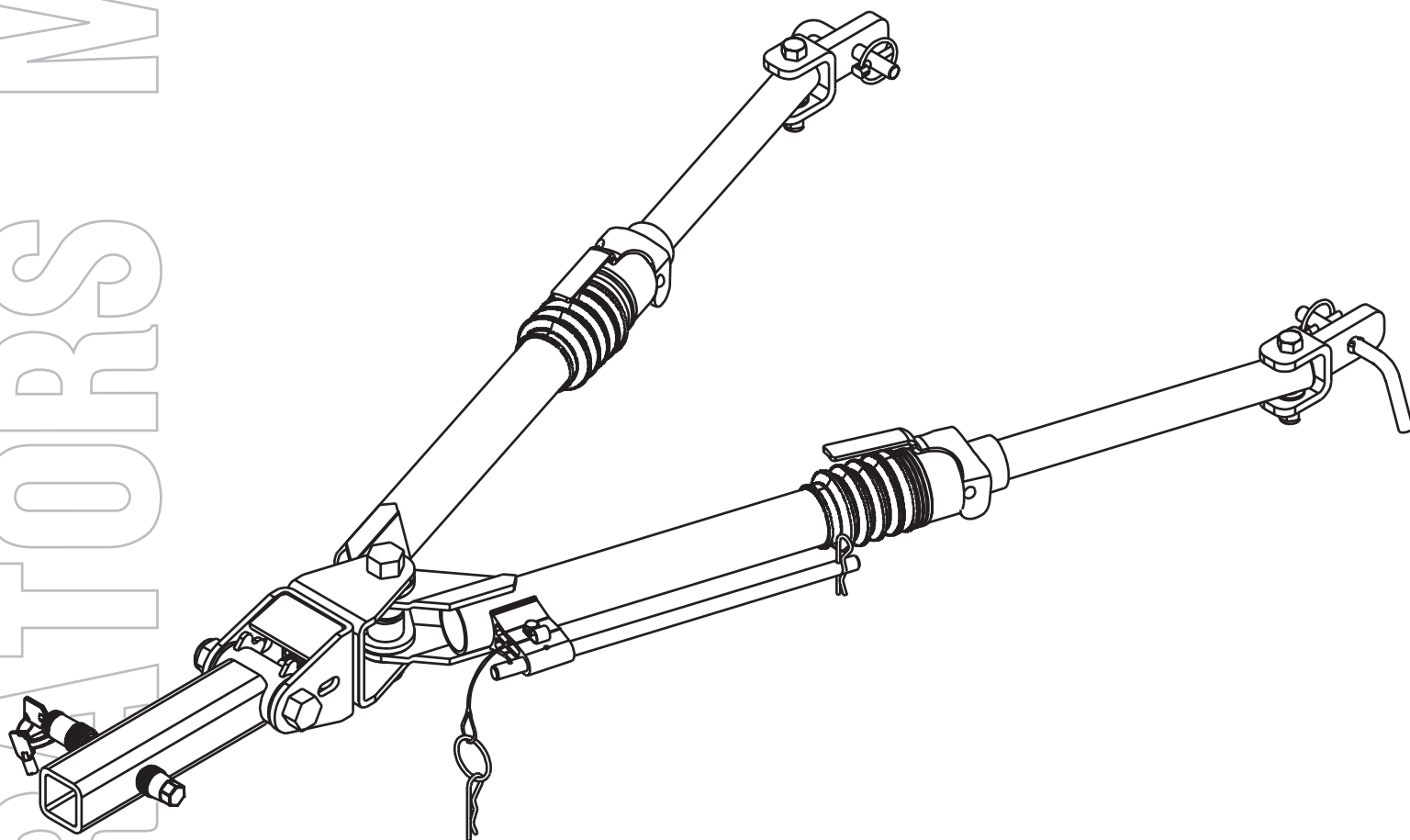

Aluminator™

Self-Aligning Tow Bar



ASSEMBLY
CALIBRATION
OPERATION
REPLACEMENT PARTS

READ complete manual CAREFULLY
BEFORE attempting operation.

Doing Our Best To Provide You The Best

OPERATORS MANUAL

⚠ WARNING: Exceeding weight limitations or not using a towing vehicle larger and at least 500 lbs. heavier than the tow bar and the towed vehicle combined can result in loss of towing vehicle control, separation of the tow bar from the towing vehicle, or separation of the towed vehicle from the tow bar, causing severe personal injury, death, and/or property damage.

TABLE OF CONTENTS

Warranty Registration	3-4
Safety Sign Location	5
Safety Definitions.....	6
Equipment Safety Guidelines & Lighting and Marking	7
Safety Sign Care & Before Operation.....	8
During & Following Operation.....	9
Highway and Transport Operations	9-10
Performing Maintenance.....	10
Safety and Maintenance.....	11
Important Notice	12
Bolt Torque.....	12
Hooking up, and Operating Instructions	13-14
Unhooking Tow Bar.....	14-15
Aluminator[®] Tow Bar Parts Breakdown	16-17
Lock Collar Assembly & Disassembly Instructions	18
Safety Cable Kit Parts Breakdown.....	19
Auxiliary Lighting Cable Kit Parts Breakdown	19
Optional Tow Bar Light Bar Parts Breakdown.....	20
Optional Extended and Drop/Lift Hitch Attachments	21
Optional Locking Pins.....	22
Warranty Statement.....	23



Warranty Registration

- Ag
- RV
- Rental
- Brakes
- Marine

4010 320th Street • Box 189 • Boyden, Iowa 51234
 Toll Free 800-54DEMCO (800-543-3626) • FAX 800-845-6420
 www.demco-products.com

	Very Satisfied	Satisfied	Dissatisfied	Very Dissatisfied
How satisfied are you with our product?	<input type="radio"/>	<input type="radio"/>	<input type="radio"/>	<input type="radio"/>
How satisfied are you with the dealership/distributor sales staff?	<input type="radio"/>	<input type="radio"/>	<input type="radio"/>	<input type="radio"/>
Dealer/Distributor Name _____ City _____ State _____				
How satisfied are you with the company sales staff?	<input type="radio"/>	<input type="radio"/>	<input type="radio"/>	<input type="radio"/>
How satisfied are you with the delivery?	<input type="radio"/>	<input type="radio"/>	<input type="radio"/>	<input type="radio"/>
Did you have any contact with a Demco Representative?	YES	NO		
If YES , how satisfied were you?	<input type="radio"/>	<input type="radio"/>	<input type="radio"/>	<input type="radio"/>
I would recommend this product to my family and friends.	YES	NO		
Would you purchase again from DEMCO?	YES	NO		
Since taking delivery, have you been contacted by the dealer?	YES	NO		
Did you have any problems with this DEMCO product?	YES	NO		
If YES , are you satisfied with the company's resolution of your problem?	<input type="radio"/>	<input type="radio"/>	<input type="radio"/>	<input type="radio"/>

Why did you purchase this product? _____

Please list the specific source of information prompting this purchase.

After purchasing this product, do you see any needed product improvement? _____ If yes, what improvement? _____

What other products would you like to see DEMCO offer? _____

Comments _____

Owner's Name: _____ **Mailing Address:** _____

City: _____ **State:** _____ **Zip Code:** _____

Model#: _____

Serial #: _____

Purchase Date: _____

Owner's Signature: _____

Please return to DEMCO By FAX or tri-folding this form to the backside, it is pre-addressed.

Postage

*Demco
4010 320th Street, Box 189
Boyden, Iowa 51234*



SAFETY SIGN LOCATIONS

Types of safety sign and locations on the *Aluminator*[™] are shown in illustration below. Good safety requires that you familiarize yourself with various safety signs, type of warning, and particular function related to that area, that requires your SAFETY AWARENESS.

WARNING

	Rating - 6500 lb. Capacity
2" Receiver hitch with proper weight rating required	
 WARNING	To Prevent Serious Injury Or Death: Do Not Exceed Capacity of Towing Hitch, Towbar, or Towing Vehicle
	DETHMERS MFG. COMPANY 4010 320th St., P.O. BOX 189 BOYDEN, IA, 51234 TOLL FREE: 1-800-54DEMCO (1-800-543-3626) www.demco-products.com
REV 2	Patent numbers: RE35,482 5,887,497 - 5,957,477 Patent pending TB21008

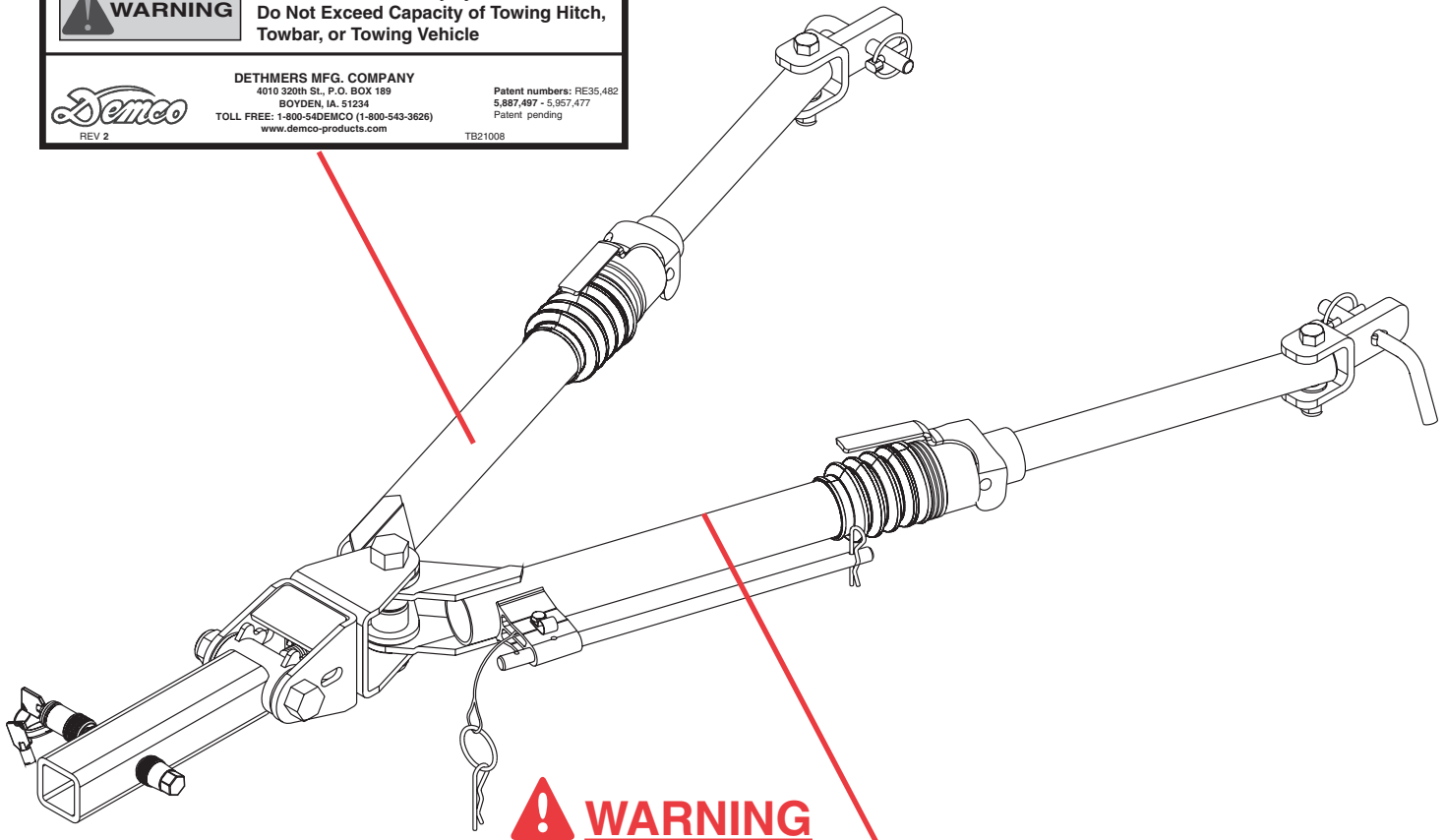

WARNING

Important operator instructions

To prevent serious injury or property damage follow these safety items:

- Before operating, read and follow operators manual.
- Be sure SAFETY CABLES are attach to both towing and towed vehicles using "criss - cross" method.
- Replace all worn or damaged parts.
- Be certain all attaching pins and safety pins are in place.
- Check all attaching points after first 5 miles and every 200 miles thereafter .
- Check clearance between vehicles in turning situation.

02/99

TB21004

SAFETY

TAKE NOTE! THIS SAFETY ALERT SYMBOL FOUND THROUGHOUT THIS MANUAL IS USED TO CALL YOUR ATTENTION TO INSTRUCTIONS INVOLVING YOUR PERSONAL SAFETY AND SAFETY OF OTHERS. FAILURE TO FOLLOW THESE INSTRUCTIONS CAN RESULT IN INJURY OR DEATH.



THIS SYMBOL MEANS

ATTENTION

BECOME ALERT

YOUR SAFETY IS INVOLVED!

SIGNAL WORDS

Note use of following signal words **DANGER**, **WARNING**, and **CAUTION** with safety messages. Appropriate signal word for each has been selected using following guidelines:

DANGER:

Indicates an imminently hazardous situation that, if not avoided, will result in serious injury or death. This signal word is to be limited to the most extreme situations typically for tow bar components which, for functional purposes, cannot be guarded.

WARNING:

Indicates a potentially hazardous situation that, if not avoided, could result in serious injury or death, and includes hazards that are exposed when guards are removed. It may also be used to alert against unsafe practices.

CAUTION:

Indicates a potentially hazardous situation that, if not avoided, may result in minor or moderate injury. It may also be used to alert against unsafe practices.

If you have questions not answered in this manual, or require additional copies, please contact your dealer or Dethmers Mfg. Co., P.O. Box 189, 4010 320th Street, Boyden, IA 51234

ph: (712) 725-2311 or (712) 725-2302 Toll Free: 1-800-543-3626 Fax: (712) 725-2380

<http://www.demco-products.com>



SAFETY...YOU CAN LIVE WITH IT



EQUIPMENT SAFETY GUIDELINES

Every year many accidents occur which could have been avoided by a few seconds of thought and a more careful approach to handling equipment. You, the operator, can avoid many accidents by observing and following precautions in this section. To avoid personal injury, study following precautions and insist those working with you, or you yourself, follow them.

Replace any caution, warning, danger or instruction safety decal that is not readable or is missing. Location of such decals is indicated in this booklet.

Do not attempt to operate this tow bar under the influence of alcohol or drugs.

Review safety instructions with all users.

Operator should be a responsible adult. **DO NOT ALLOW PERSONS TO OPERATE OR ASSEMBLE THIS TOW BAR UNTIL THEY HAVE DEVELOPED A THOROUGH UNDERSTANDING OF SAFETY PRECAUTIONS AND HOW IT WORKS.**

Do not paint over, remove, or deface any safety signs or warning decals on your tow bar. Observe all safety signs and practice instructions on them.

Never exceed limits of a tow bar. If its ability to do a job safely is in question **DON'T TRY IT.**



LIGHTING AND MARKING

It is the responsibility of owner to know lighting and marking requirements of local highway authorities and to install and maintain equipment to provide compliance with regulations.

Light bar kits are available from your dealer or from manufacturer.



SAFETY SIGN CARE

- Keep safety signs clean and legible at all times.
- Replace safety signs that are missing or have become illegible.
- Replacement parts that displayed a safety sign should also display current sign.
- Safety signs are available from your distributor, dealer parts department, or factory.

How to install safety signs:

- Be sure installation surface is clean and dry.
- Decide on exact position before you remove backing paper.
- Remove smallest portion of split backing paper.
- Align decal over specified area and carefully press small portion with exposed sticky backing in place.
- Slowly peel back remaining paper and carefully smooth remaining portion of decal into place.
- Small air pockets can be pierced with a pin and smoothed out using piece of decal backing paper.



REMEMBER

Your best assurance against accidents is a careful and responsible operator. If there is any portion of this manual or function you do not understand, contact your local authorized dealer or manufacturer.



BEFORE OPERATION:

- Carefully study and understand this manual.
- Give tow bar a visual inspection for any loose bolts, worn parts, or cracked welds, and make necessary repairs. Follow maintenance safety instructions included in this manual.
- Be sure there are no tools lying on tow bar, towing unit or towed vehicle.
- Do not use tow bar until you are sure that area is clear, especially around children and animals.
- Don't hurry learning process or take tow bar for granted. Ease into it and become familiar with your new tow unit.
- Practice operation of your tow unit and its attachments. Completely familiarize yourself and other operators with its operation before using.
- Securely attach to towing unit. Use an appropriately sized and rated hitch ball and/or a class III, class IV receiver and attach safety cables.
- Criss cross safety cables under tow bar, secure to mounting loops on towing vehicle.
- Do not allow anyone to stand between vehicles when backing up.
- Make sure tow rating on towing unit is high enough for what it is towing.
- To prevent swaying of towed vehicle insure all tires are inflated to specifications. Failure to inflate tires evenly will result in towed vehicle to pull unevenly.



DURING OPERATION

- Always follow state and local regulations regarding auxiliary lighting when towing. Be sure to check with local law enforcement agencies for your own particular regulations. Only safety cables (not elastic or nylon/plastic tow straps) should be used to retain connection between towing unit and towed vehicle in event of separation.
- Do not load towed vehicle with cargo. Towed vehicles exceeding weight limits will overload tow bar and may cause serious injury and damage.
- Beware of bystanders, **PARTICULARLY CHILDREN!** Always look around to make sure it is safe to start engine of towing unit and moving towed vehicle. This is particularly important with higher noise levels, as you may not hear people shouting.
- **NO PASSENGERS ALLOWED-** Do not carry passengers anywhere on or in towed vehicle.
- When halting operation, even periodically, set towing unit's parking brake, shut off engine, and **remove ignition key**.
- Be extra careful on inclines.
- **MANEUVER TOWING UNIT AT SAFE SPEEDS.**
- Avoid overhead wires or other obstacles. Contact with overhead lines could cause serious injury or death.
- Avoid loose gravel, rocks, and holes; they can be dangerous for unit operation or movement.
- Allow for unit length when making turns.
- Do not work under raised components or attachments unless securely positioned and blocked.
- Keep all bystanders and pets clear of work area.
- Operate towing unit from operators seat only.
- As a precaution, recheck hardware on tow bar every 200 miles, and correct all problems. Follow maintenance safety procedures.



FOLLOWING OPERATION

- Following operation, or when unhooking, stop towing vehicle, set parking brake, shut off engine and **remove ignition key**.
- Store tow bar in area away from human activity.
- Do not permit children to play on or around stored tow bar.
- Make sure parked vehicle is on hard, level surface.
- Wheel chocks may be needed to prevent vehicle from rolling.



HIGHWAY AND TRANSPORT OPERATIONS

- Adopt safe driving practices:
 - Always drive at safe speed relative to local conditions and ensure that your speed is low enough for an emergency stop.

- Reduce speed prior to turns to avoid risk of overturning.
- Always keep towing unit in gear to provide engine braking when going downhill.
Do not coast.
- **Do not drink and drive!**
- Comply with state and local laws governing highway safety.
- Local laws should be checked for all highway lighting and marking requirements.
- Plan your route to avoid heavy traffic.
- Be a safe and courteous driver. Always yield to oncoming traffic in all situations, including narrow bridges, intersections, etc.
- Watch for obstructions overhead and to both sides while towing vehicle.
- Operate with maximum visibility at all times. Make allowances for increased length and weight when making turns and stopping.



PERFORMING MAINTENANCE

- Good maintenance is your responsibility. Poor maintenance is an invitation to trouble.
- Make sure there is plenty of ventilation. Never operate engine of towing unit in a closed building. Exhaust fumes may cause asphyxiation.
- Before working on tow bar, stop towing vehicle, set parking brake, turn off engine and **remove ignition key.**
- Always use proper tools or equipment for job at hand.
- Use extreme caution when making adjustments.
- Follow torque chart in this manual when tightening bolts and nuts.
- After servicing, be sure all tools, parts and service equipment are removed.
- Do not allow grease or oil to build up.
- When replacing bolts, refer to owners manual.
- Refer to bolt torque chart for head identification marking.
- Where replacement parts are necessary for periodic maintenance and servicing, genuine factory replacement parts must be used to restore your tow unit to original specifications. Manufacturer will not claim responsibility for use of unapproved parts and/or accessories or other damages as a result of their use.
- If tow unit has been altered in any way from original design, manufacturer does not accept any liability for injury or warranty.
- A fire extinguisher and first aid kit should be kept readily accessible while performing maintenance on this tow bar.

⚠ WARNING: FAILURE TO FOLLOW THESE INSTRUCTIONS CAN RESULT IN LOSS OF TOWING VEHICLE CONTROL, SEPARATION OF THE TOW BAR FROM THE TOWING VEHICLE, SEPARATION OF THE TOWED VEHICLE FROM THE TOW BAR, CAUSING SEVERE PERSONAL INJURY, DEATH, OR PROPERTY DAMAGE.

⚠ WARNING: ADDITIONAL SAFETY ITEMS

Safety is of utmost importance at all times. To prevent personal injury or property damage, observe the following.

- Before allowing anyone to hook up or operate the *Aluminator™*, be sure they have read and understand the proper operating procedure.
- This unit must be used with a Class III, 5,000 lb. Hitch or higher.
- Be sure the steering components of the towed vehicle are properly aligned.
- The male receiver tube must fit snugly in the hitch receiver and the safety pin must be in position to lock the receiver and tube together.
- **NOTE:** This unit can be backed up in moderate increments. Any severe backwards cornering could result in damage to the *Aluminator™* and/or towed vehicle chassis.
- **For automatic transmissions:** Consult your vehicle owners manual for towing suitability with the drive shaft connected. Otherwise, the towed vehicle will have to be equipped with a transmission pump or drive shaft disconnect.
- Be sure the **SAFETY CABLES w/retainers** are hooked to both the towing and towed vehicles using the criss-cross method.
- Do not load the towed vehicle with anything as you may exceed the towing capacity of the tow bar.
- Check to make sure that all lights are in proper working order.
- Make sure the optional light bar is fastened securely at the rear of the towed vehicle.

MAINTENANCE

Periodically check all bolts and nuts to ensure proper tension or torque.

Check all pivot points for wear or breakage.

Replace any worn or damaged parts with O.E.M. parts only.

An occasional spray of lubricant may be required inside the Lock Collar of the extending legs.

DO NOT lubricate any of the pivot points of the *Aluminator™*. These are self-lubricating washers and your towbar could lose its self-supporting ability.

Keep the *Aluminator™* covered when stored on or off the towing vehicle.

If the Lock Collars become limited in their movement they may require disassembly using the instructions provided on page 18.

Make sure all bolts are properly tightened and those requiring a set torque are up to specifications:

Center Horizontal Pivot Bolt - 40 ft./lbs.

Front Vertical Pivot Bolt - 75 ft./lbs.

(This bolt can be tightened to a torque range of 60 ft./lbs - 100 ft./lbs for the ease of maneuverability)

Rear Horizontal Pivot Bolt - 60-75 ft./lbs.

(See diagram on Page 13)

Thank you for Purchasing **Demo** Products.

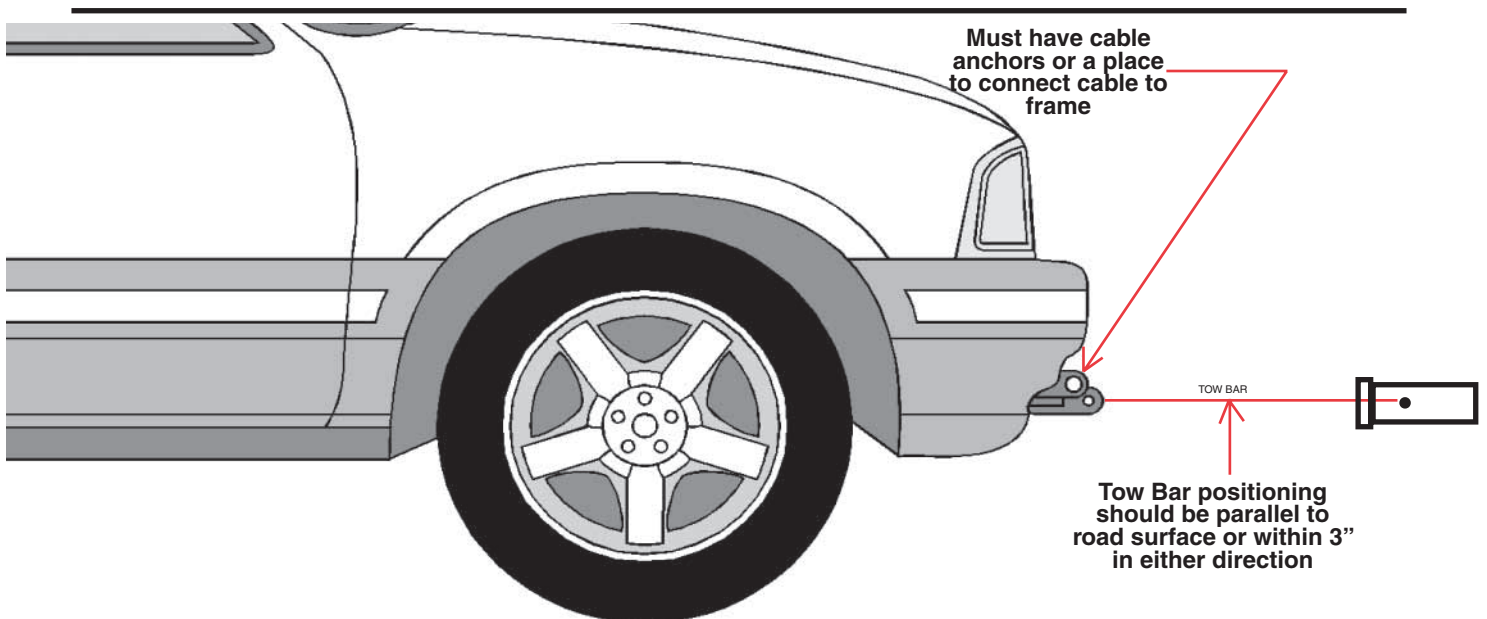

Important Notice!

**Be sure towed vehicle is suitable or adaptable for towing.
A few models are not towable!**

Be sure to check if towed vehicle requires additional equipment such as a transmission lube pump, free-wheel hubs, driveline disconnect or axle locks. Failure to properly equip towed vehicle will result in severe damage to towed vehicle's transmission.

Be sure that towed vehicle's steering wheel is unlocked and free to turn. Check manufacturer's specifications for the proper way to unlock steering wheel.

Be sure to check that receiver on towing vehicle is not inset to far. When attaching a Demco towing product it is important that turning clearance is adequate. A receiver that is inset to far on a towing vehicle will shorten turning radius. Failure to check this may result in towing or towed vehicle to be damaged. It may be necessary to install a receiver extension to allow for proper turning clearance.

BOLT TORQUE TORQUE DATA FOR STANDARD NUTS, BOLTS, AND CAPSCREWS.

Tighten all bolts to torques specified in chart unless otherwise noted. Check tightness of bolts periodically, using bolt chart as guide. Replace hardware with same grade bolt.

NOTE: Unless otherwise specified, high-strength Grade 5 hex bolts are used throughout assembly of equipment.

Bolt Torque for Metric bolts *

"A"	CLASS 8.8		CLASS 9.8		CLASS 10.9	
	lb-ft	(N.m)	lb-ft	(N.m)	lb-ft	(N.m)
6	9	(13)	10	(14)	13	(17)
7	15	(21)	18	(24)	21	(29)
8	23	(31)	25	(34)	31	(42)
10	45	(61)	50	(68)	61	(83)
12	78	(106)	88	(118)	106	(144)
14	125	(169)	140	(189)	170	(230)
16	194	(263)	216	(293)	263	(357)
18	268	(363)	--	--	364	(493)
20	378	(513)	--	--	515	(689)
22	516	(699)	--	--	702	(952)
24	654	(886)	--	--	890	(1206)

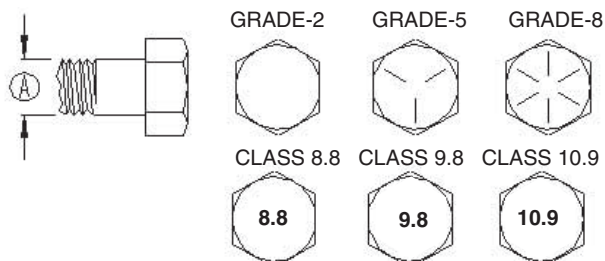

Torque Specifications

Torque figures indicated are valid for non-greased or non-oiled threads and heads unless otherwise specified. Therefore, do not grease or oil bolts or capscrews unless otherwise specified in this manual. When using locking elements, increase torque values by 5%.

* GRADE or CLASS value for bolts and capscrews are identified by their head markings.

Bolt Torque for Standard bolts *

"A"	GRADE 2		GRADE 5		GRADE 8	
	lb-ft	(N.m)	lb-ft	(N.m)	lb-ft	(N.m)
1/4"	6	(8)	9	(12)	12	(16)
5/16"	10	(13)	18	(25)	25	(35)
3/8"	20	(27)	30	(40)	45	(60)
7/16"	30	(40)	50	(70)	80	(110)
1/2"	45	(60)	75	(100)	115	(155)
9/16"	70	(95)	115	(155)	165	(220)
5/8"	95	(130)	150	(200)	225	(300)
3/4"	165	(225)	290	(390)	400	(540)
7/8"	170	(230)	420	(570)	650	(880)
1"	225	(300)	630	(850)	970	-(1310)

SAFETY CABLE & LIGHT CABLE INSTALLATION

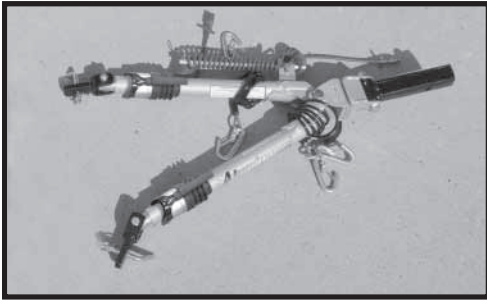

Step 1. Remove safety cables from box and coil a cable around each leg of the tow bar, starting near the pivot point. Install the light cable (optional) by placing the coil over the wire support rod. Secure the cable with the cable anchor located on left connecting leg lock pin mount. Remove 1/4" bolt, place anchor over coil of cable and replace bolt. This will prevent the cable from pulling off and becoming damaged.

HOOKING UP THE VEHICLE TO BE TOWED

Refer to load limits on inside of front cover.

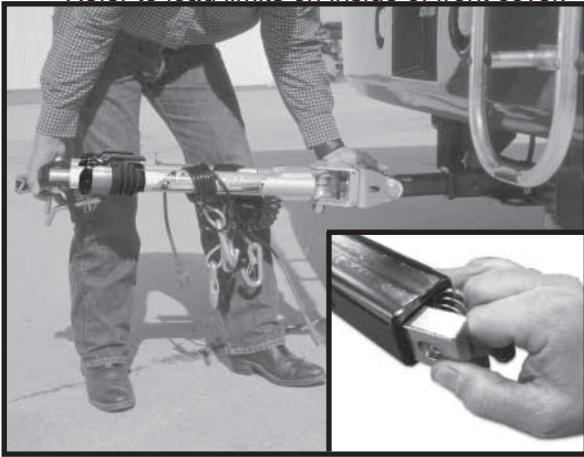

Step 2. Insert the lock pin block and spring into the *Aluminator™* receiver tube and line up block with hole in tube. Insert the *Aluminator™* into a Class III or IV hitch.

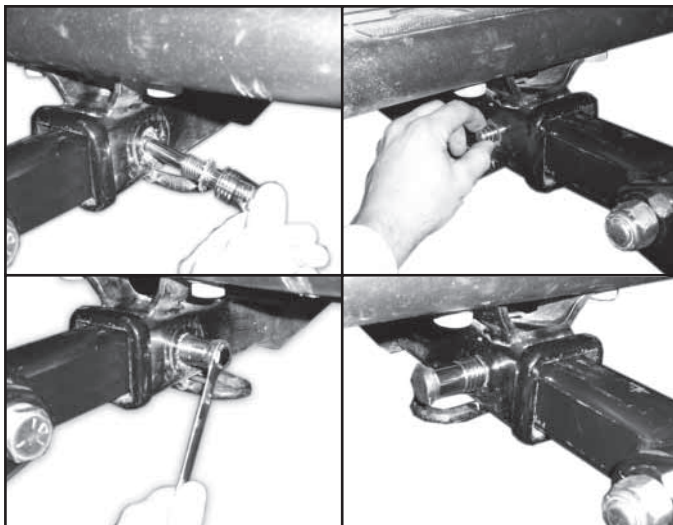

Step 3. Insert locking pin with star washer through receiver on the block side and thread in pin until passes through. Slide pin bushing over pin and into hitch receiver. Tighten pin use 5/8" wrench and install lock on pin.

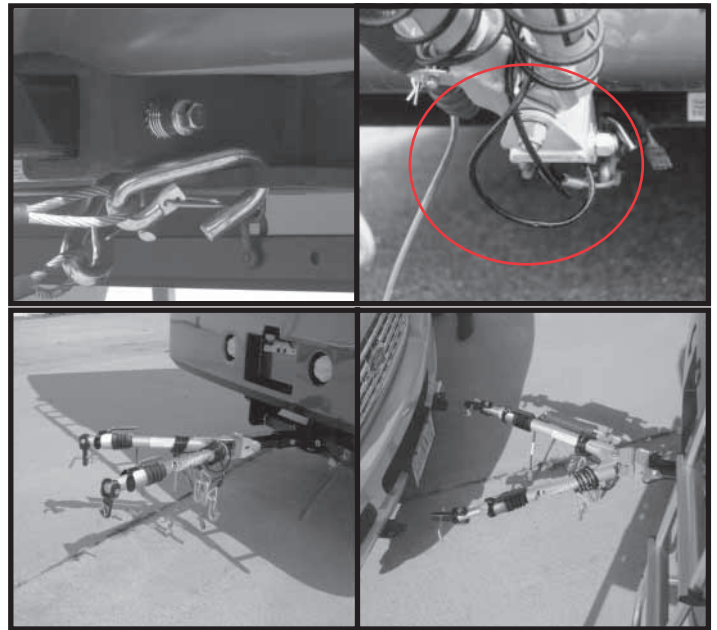

Step 4. Position the vehicle to be towed approx. 24" behind the towing vehicle. The vehicles **do not** have to be in straight alignment to complete the hook-up. **Engage towed vehicle and towing vehicle parking brake.**



Step 5. Slide and twist the legs into position to attach them to the baseplate on towed vehicle. Secure to baseplate using the two attaching pins and 1/4" quick-lock pin. Attach safety cables (see below). Now connect the lighting cable between the towing vehicle and the towed vehicle lighting system or optional light bar. The coiled section of the cable will be stored on the support rod of the left connecting leg. **Towing vehicle must be larger and at least 500 lbs. heavier than the towed vehicle and tow bar combined.**



quick-lock pin must be closed properly. Fold ring of Quick-Lock Pin to the side of the pin that allows ring to snap against pin. If you have folded its ring the wrong way it will not snap against pin.

UNHOOKING THE TOWED VEHICLE

Step 1. Begin unhooking your unit by first applying both vehicle parking brakes and unhook your lighting and safety cables. **Failure to have parking brakes applied could allow towed vehicle to roll forward. This could result in limited space between towing vehicle and towed vehicle.**

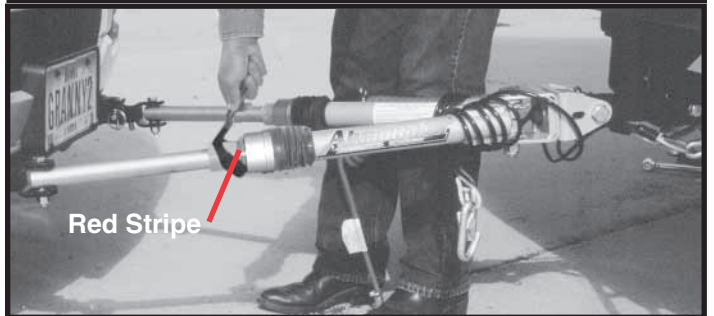

Step 2. Use the Lock Collar Release lever to relieve any pressure in the connecting legs between the two vehicles by lifting up on handle.

Step 3. Remove pins that attach tow bar to towed vehicle. *Aluminator™* will remain in position. Slide the extendable legs back into tube. Position electrical cable on storage rod and insert pin to prevent cable from sliding off.

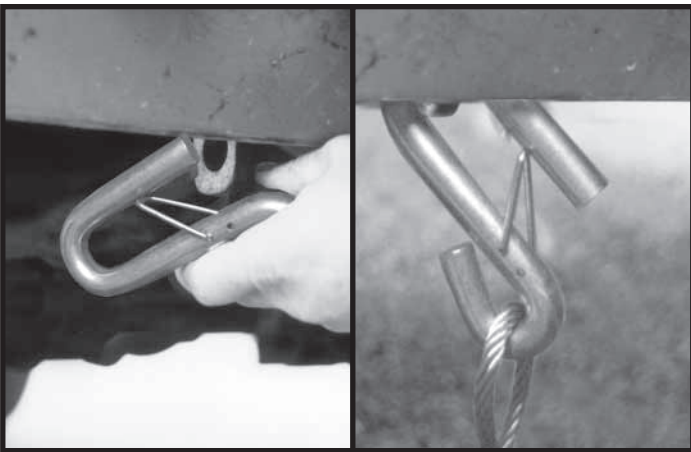
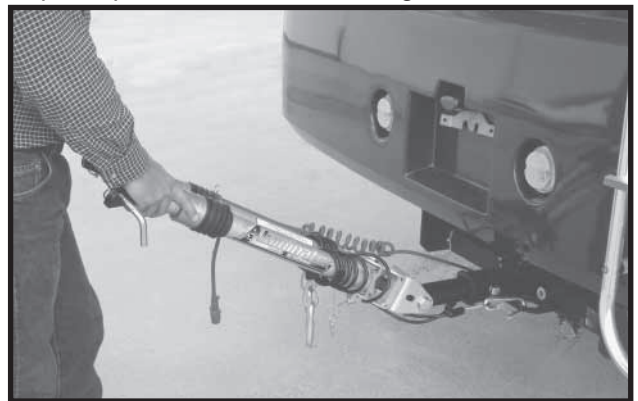

Step 6. Hook safety cables to chain anchor of baseplate. **Note:** Make sure safety clip is in working order.

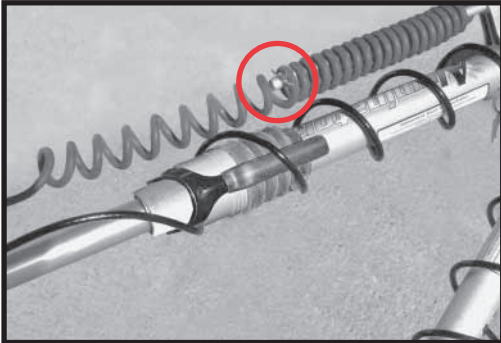

Step 7. Leave the electrical cable storage pin (circled above) out for the locking procedure in step 6. When step 6 is completed, position cable on storage rod leaving enough slack, and insert pin.

Step 8. Once you are secured to the tow bar, release towed vehicle parking brake, and slowly back up the towed vehicle straight back until one leg latches. Determine which leg latched by having an assistant tell you. If you are by yourself put towed vehicle in neutral or park, and apply parking brake. Get out and check to see which leg latched. You can tell this by which leg no longer has red stripe showing. To latch the second leg, turn the top of towed vehicle's steering wheel into the direction of the leg that first latched, and slowly back up again. This will latch the second leg. Once both legs are latched, straighten wheels on towed vehicle, shut vehicle off. If manual transmission, shift to neutral, unlock steering wheel and make sure parking brake is released. **Note: For four wheel drive units, shift transfer case into neutral also. Reminder:** Consult vehicle's manufacturer for towing suitability of manual or automatic transmission vehicles.

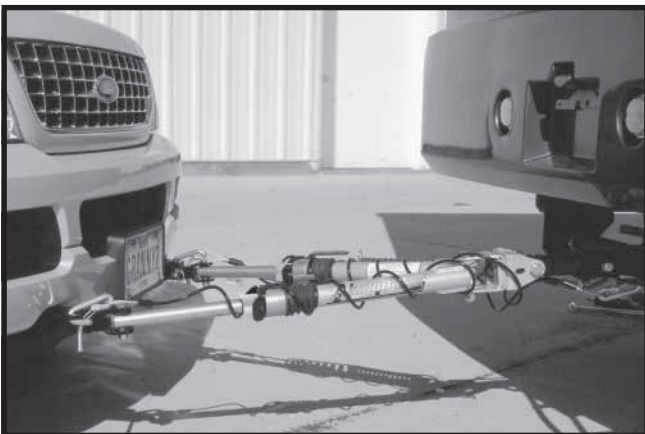

Step 4. Now fold both legs together and push them upward.



Step 5. Rotate them counter-clockwise into the storage position. The unit is self supportive in this position. Insert the small hairpin into the lockpin inside the front yoke. Cover your *Aluminator™* and you are ready to drive your vehicle.

NOTE: Picture shown in 90 degree position. *Aluminator™* will also store in 45 degree position.

NOTE: If you need to store your *Aluminator™* on the opposite side you must rotate the rear yoke 180° and rotate the legs clockwise into the storage position.

PARTS BREAKDOWN

Order No. 9511007

REF. NO.	PART NO.	QTY.	DESCRIPTION
1.	03796-81	1	Male Receiver with bushings
2.	03808	2	Crosstube Bushing Only
3.	07161-95	2	3/4"-10NC x 4-1/2" Hex Head Bolt (Gr.5)
4.	02961	2	3/4"-10NC Nylon Insert Locknut
5.	09386-89	1	Front Yoke
6.	09390-89	1	Rear Yoke
7.	09404	1	3/4"-16NF x 2-1/2" Hex Hd. Bolt (Gr.5)
8.	00116	1	5/32" x 1-1/2" Ig. Cotter Pin
9.	03806	2	Yoke Washer
10.	03797-95	1	Thrust Plate
11.	07218	1	3/4"-16NF Hex Jam Nut
12.	03810	1	Connecting Arm Bushing
13.	12961	2	1-3/4" Round Vented Caplug
14.	04795	2	1/2"-13NC x 1" Hex Head Bolt(Gr.5)
16.	12535	2	Stop Washer
17.	09333	1	Neoprene O-Ring (1/8" x 1-1/4" OD)
18.	03807	4	Ear Washer
19.	12544-89	1	Left Front Connecting Leg
20.	12545-89	1	Right Front Connecting Leg
21.	07221	1	Light Cable Anchor
22.	00684	1	1/4"-20NC x 1-1/2" Hex Head Bolt (Gr.5)
23.	02772	1	1/4"-20NC Nylon Insert Locknut
24.	07222	1	Lanyard Cable
25.	00182	2	1/8" Small Hair Pin
26.	07223	1	5/32" x 3/4" Roll Pin
27.	11210-89	1	Wire Support
28.	12458	4	Lock Pawl
29.	07224	2	Leg Seal
30.	03872	2	Coil Spring
31.	10112-93	2	Lock Collar
32.	03873	2	Snap Ring
33.	12543-89	2	Rear Connecting Leg
34.	03809	4	Connecting Clevis Washer
35.	03803-81	2	Connecting Clevis
36.	07164-95	2	1/2"-13NC x 3" Hex Head Bolt (Gr.5)
37.	02178	2	1/2"-13NC Nylon Insert Locknut
38.	09384	4	3/4" 21 Ga. NR Machine Washer SS
39.	03878-95	2	Attaching Pin
40.	02397	2	1/4" Quick Pin
41.	12530-95	1	Lock Collar Release Tool w/Grip
42.	02243	1	Black Handle Grip Only
43.	5846	1	Lock Pin F/ Reciever
44.	12431	-	Rplacement Key
45.	07225	1	Split Ring

REF. NO.	PART NO.	QTY.	DESCRIPTION
46.	09343	6	Plastic Bearing (Nyliner)
47.	10117	2	O-ring 1.862 I.D. x .103 Cross Section
48.	11770	1	Washer, .782 ID, Stainless Steel
49.	11825	2	Protective Bellows Boot
50.	11874	4	Cable Tie
-	9523042	-	Vinyl Storage Cover (Optional-not shown)
-	10173	1	Copper Anti-seize .25 oz

Please order replacement parts by PART NO. and DESCRIPTION.

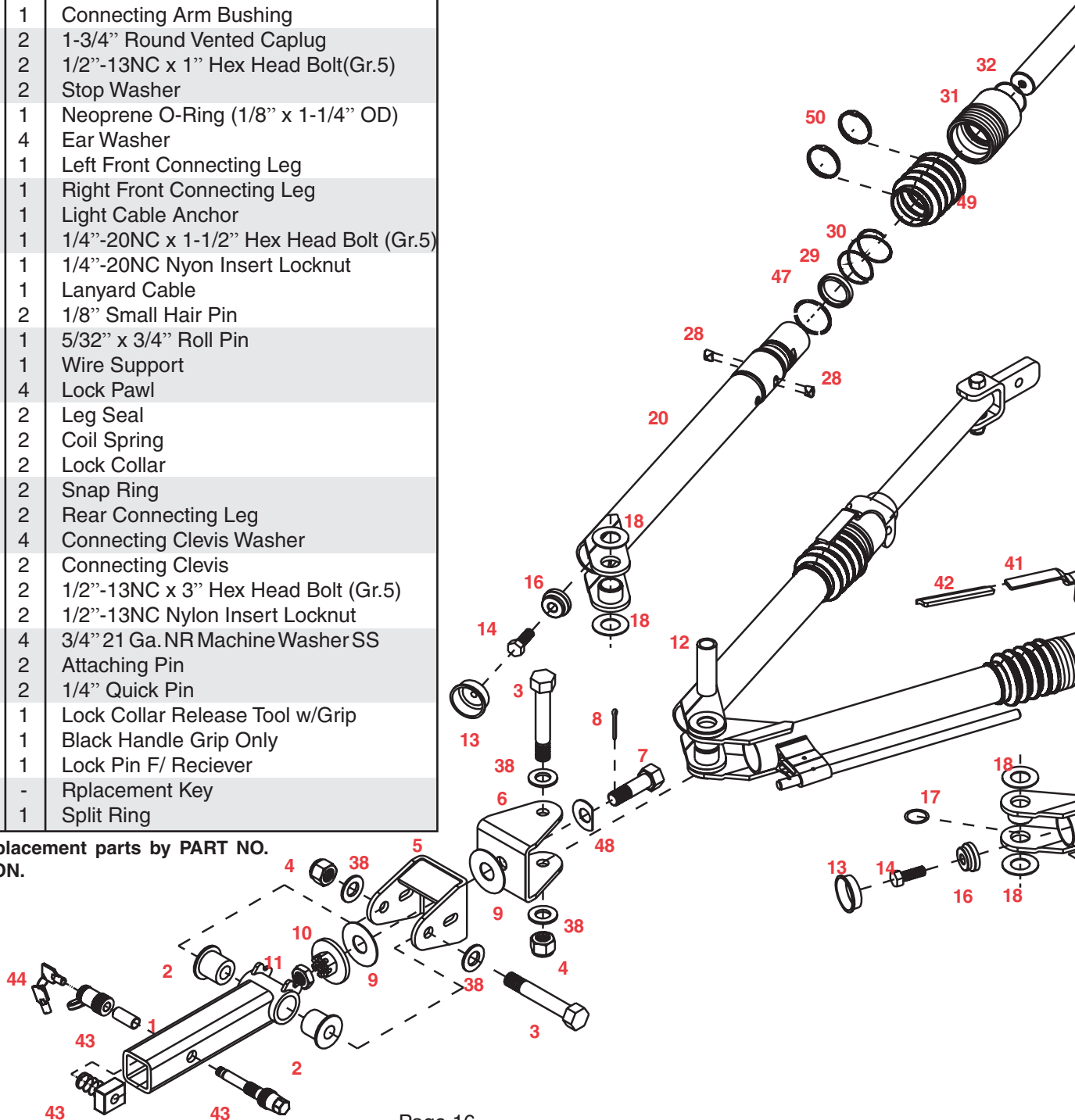

Please order replacement parts by PART NO. and DESCRIPTION.

Demco Aluminator

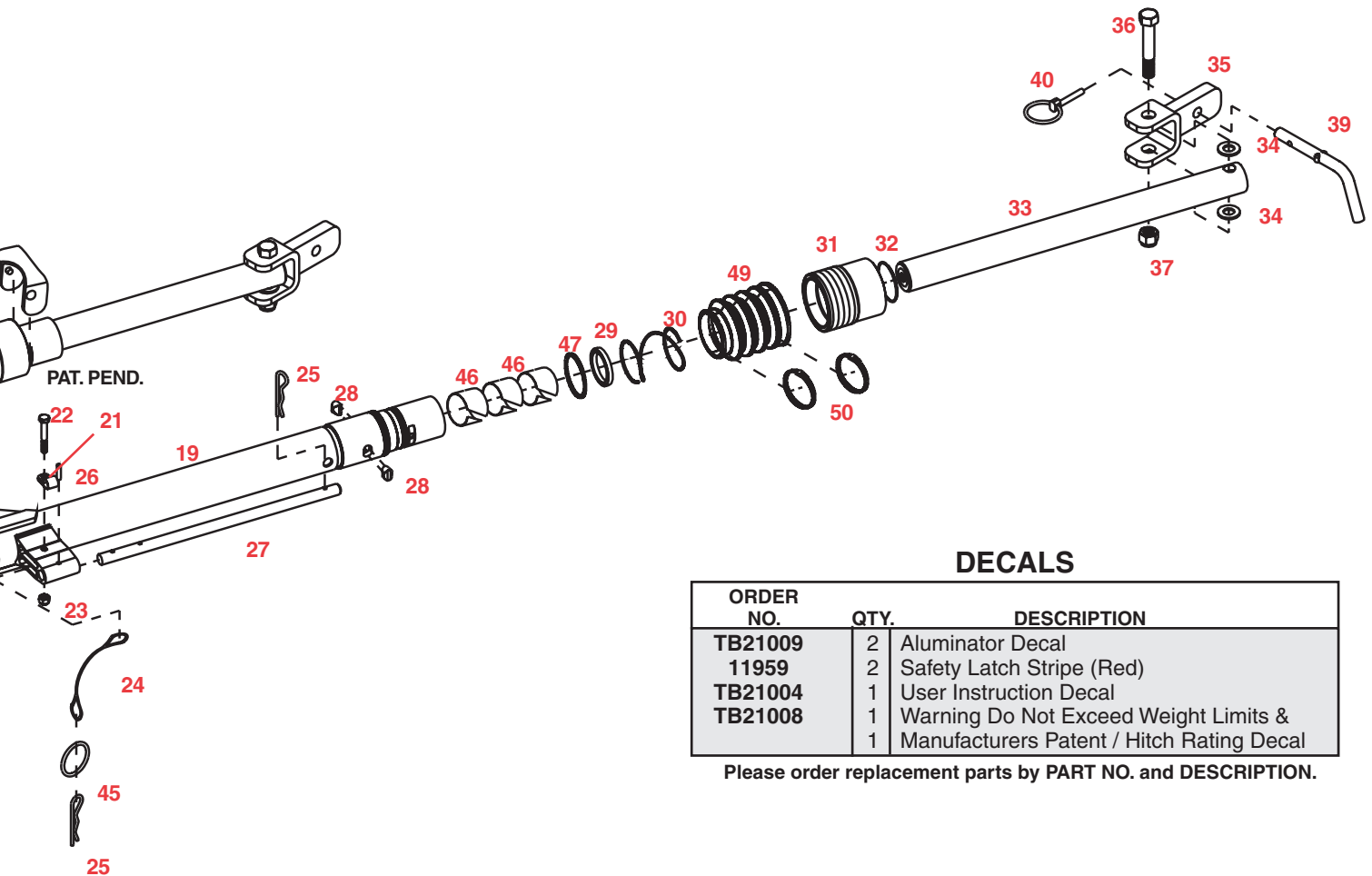
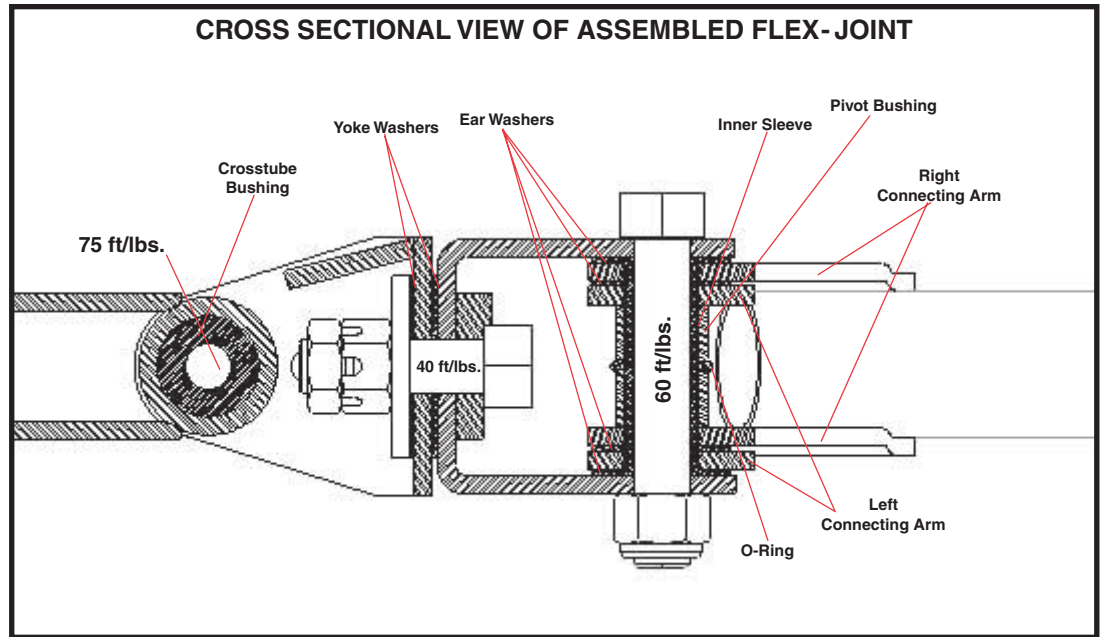
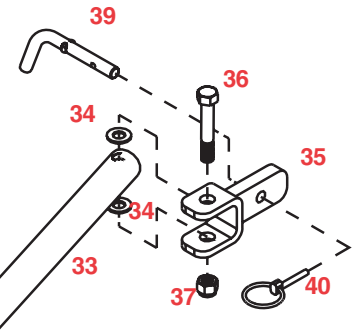

DECALS

ORDER NO.	QTY.	DESCRIPTION
TB21009	2	Aluminator Decal
11959	2	Safety Latch Stripe (Red)
TB21004	1	User Instruction Decal
TB21008	1	Warning Do Not Exceed Weight Limits & Manufacturers Patent / Hitch Rating Decal

Please order replacement parts by PART NO. and DESCRIPTION.

LOCK COLLAR MAINTENANCE INSTRUCTIONS

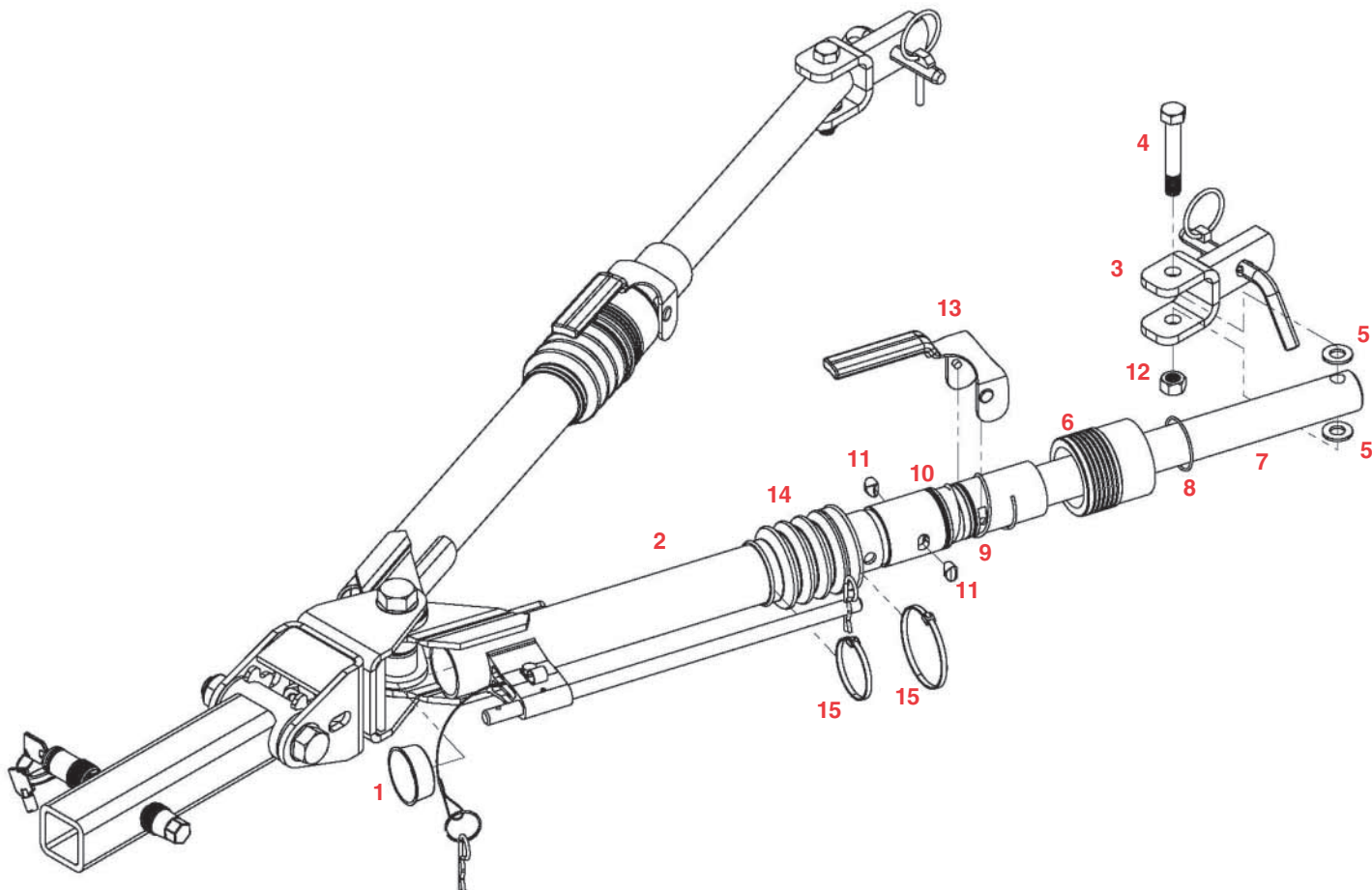

DISASSEMBLY:

1. Leave *Aluminator*® on towing vehicle or clamp hitch tube in heavy-duty vise.
2. With a screw driver, pry up on bottom of release handle (#13) ear to remove handle. Remove bellows boot (#14) from lock collar (#6) and slide bellows boot back. Pull back the Lock Collar (#6) and push the Rear Leg (#7) approximately halfway in. This will hold the Lock Collar in the release position.
3. Remove the snap-ring (#8).
4. While holding Lock Collar, pull rear connecting leg outward to the latch position and collar will then slide off outer tube and hang on rear leg. Inside of lock collar (#6) can be cleaned at this time. Lock pawls (#11) can be removed at this time for cleaning by pushing rear leg (#7) back into outer tube about 1", this will push lock pawls out for removal. If not removing shaft go to step 7. **For shaft removal or o-ring replacement;** Remove caplugs (#1) from the Front Connecting Leg Tube (#2) and unbolt Connecting Clevis (#3) from Rear Connecting Leg (#7) by removing the 1/2" x 3" bolts (#4), washers (#5) and locknuts (#12).
5. Remove Lock Collar (#6), Lock Spring (#9), and O-ring (#10).
6. Slide out Rear Leg, be careful not to damage the shaft seal.
7. Clean o-ring groove area and oval hole in outer tube and lock pawls. Inspect all parts for excessive wear.
8. Reassemble this leg, If shaft not removed, go to step 3 of reassembly. Repeat steps for other side.

REASSEMBLY:

1. Reinstall o-ring (#10) on outer tube. Lubricate only the o-ring with a lite coat of copper anti-seize (included with *Aluminator*® Part number 10173). (Note location in Figure A)
2. Slide rear leg into front connecting leg tube, being careful not to damage shaft seal (see Figure A). A slight twisting motion will aid in the installation. Slide the rear leg in until the shaft groove matches up with the square pawl holes.
3. Replace the two lock pawls (#11) into the tube insert.
4. Replace Lock Spring (#9) and Lock Collar (#6).
NOTE: The smaller end of the tapered lock spring (#9) must be against the Lock Insert part of the Front Connecting Leg.
5. Pull Lock Collar back and slide the rear leg in approximately halfway. This will hold the Lock Collar in the release position.
6. Replace the snap-ring (#8).
7. Replace rubber bellows boot (#14) to lock collar (#6) with nylon ties (#15).
8. Reattach Connecting Clevis (#3) on Rear Connecting Leg (#7) with the 1/2" x 3" bolts (#4), washers (#5) and locknuts. Tighten bolts until clevises are just snug.
9. Reinstall the caplug (#1).
10. Reattach release handle (#13) by tapping on with a rubber mallet.

SAFETY CABLES
(STANDARD FOR *Aluminator™* & REQUIRED FOR TOWING)

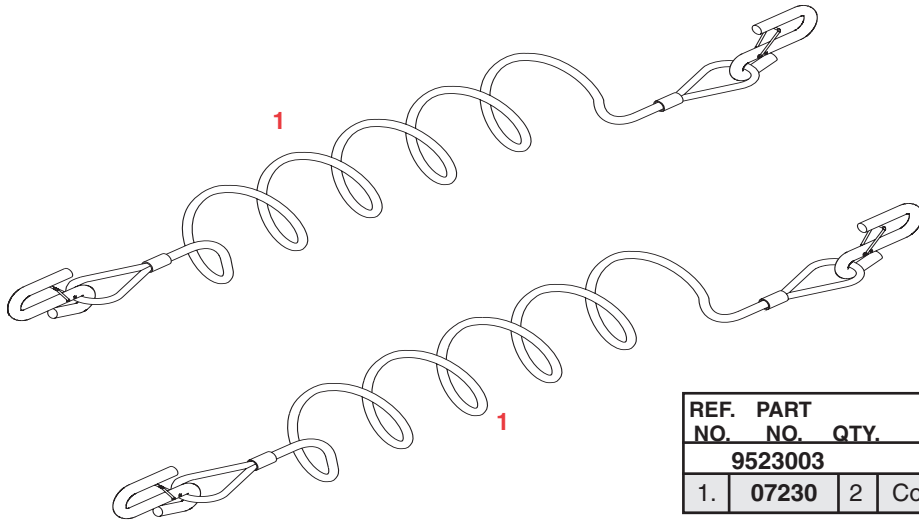

PARTS LIST

REF. NO.	PART NO.	QTY.	DESCRIPTION
	9523003		Safety Cable Kit (complete)
1.	07230	2	Coiled Safety Cable w/Hooks

Please order replacement parts by PART NO. and DESCRIPTION.

AUXILIARY LIGHTING CABLE
(OPTIONAL)



Possible mounting location for lighting receptacle in vehicle air dam.

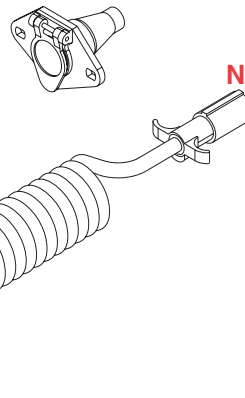
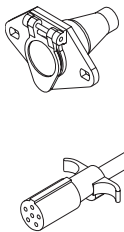

NOTE: To be used with optional Light Bar, the ends will have to be cut off light bar harness. This end will then need to be wired to the receptacle of the auxiliary lighting kit.

NOTE: For replacement parts, call original manufacturer or DEMCO at 1-800-543-3626

AVAILABLE WIRING KITS

ORDER NO.	DESCRIPTION
9523004	4-Way Auxiliary Coiled Lighting Cable w/recpt.
9523006	6-Way Auxiliary Coiled Lighting Cable w/recpt.
9523009	9523004 & Towed Vehicle Tail Light Wiring/Diode Kit
9523010	Towed Vehicle Tail Light Wiring/Diode Kit Only
9523011	9523006 & Towed Vehicle Tail Light Wiring/Diode Kit

Please order replacement parts by PART NO. and DESCRIPTION.

OPTIONAL LIGHT BAR (KKLB) PARTS BREAKDOWN

COLOR CODE FOR WIRING HARNESS

WHITE	Ground
BROWN	Tail Lights, License Plate Lights, Light Cluster Bar & Clearance Lights
YELLOW	Left Turn and Stop
GREEN	Right Turn and Stop

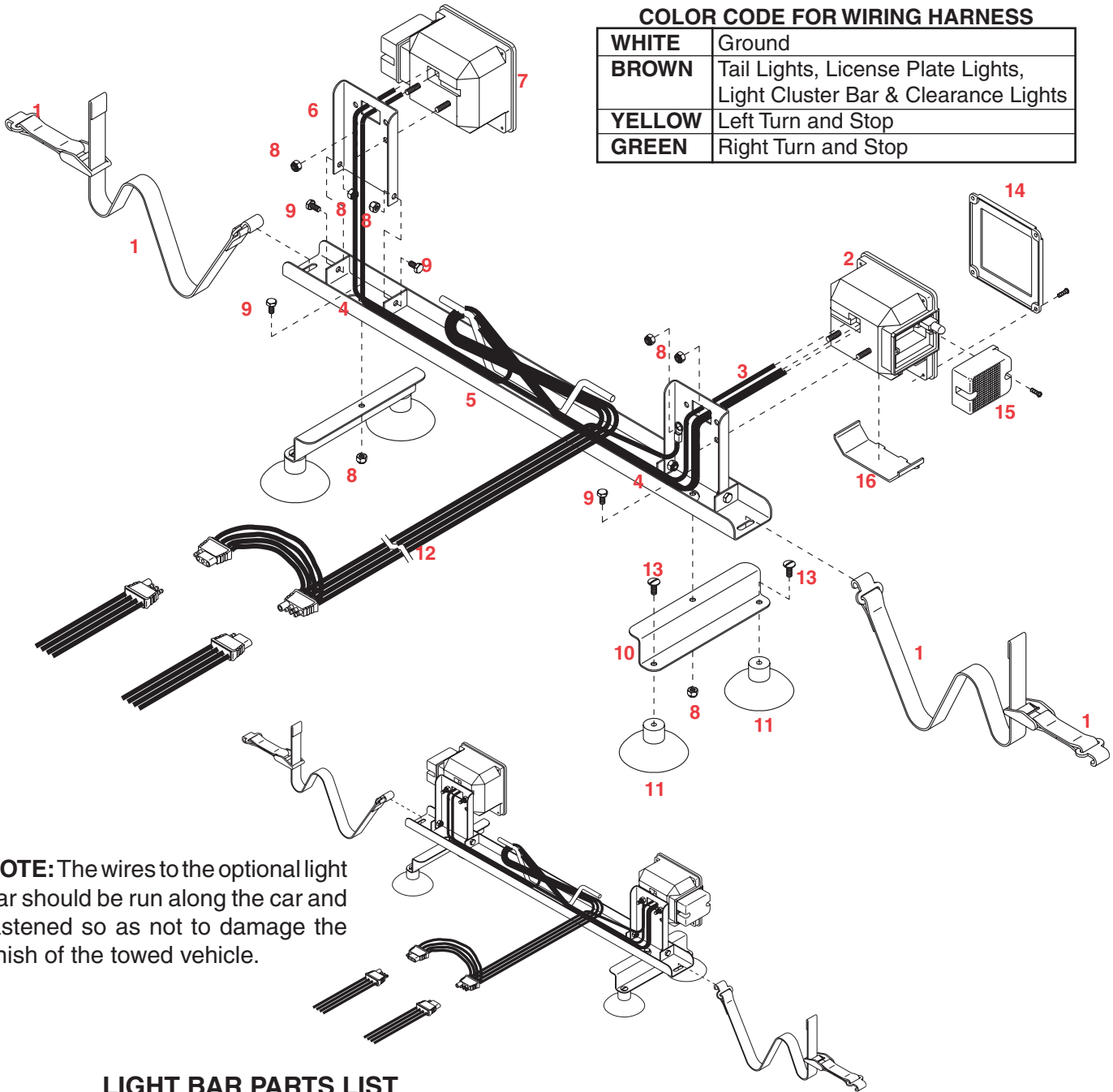

NOTE: The wires to the optional light bar should be run along the car and fastened so as not to damage the finish of the towed vehicle.

LIGHT BAR PARTS LIST

REF. NO.	PART NO.	QTY.	DESCRIPTION
	KKLB		Aluminator™ Light Bar (complete)
1.	01772	2	Nylon Security Strap with hooks & tightener
2.	01857	1	Left Tail/ Brake and Signal Light w/Lenses
3.	01773	1	Brown Jumper Wire
4.	01886	4	Wire Holder (metal)
5.	02385	1	Light Bar Framework
6.	02386	2	Adjustable Light Bracket
7.	01856	1	Right Tail/ Brake and Signal Light w/Lenses
8.	02772	10	1/4"-20UNC Nylon Insert Locknut
9.	00092	6	1/4"-20UNC x 1/2" Hex Head Bolt
10.	01777	2	Light Bar "Z" Bracket
11.	01778	4	3" Suction Cup w/Bolt (#13)
12.	02198	1	Light Bar Wiring Harness (new style)
13.	00068	4	1/4"-20UNC x 3/4" Hex Head Bolt
14.	01911	-	Large Red Lens
15.	01912	-	Small Red Lens
16.	01890	-	Clear Lens

Please order replacement parts by PART NO. and DESCRIPTION.

TESTING LIGHTS BEFORE USE

1. With headlights in "ON" position, the tail lights and the clearance lights should be lighted.
2. Start engine and have someone depress brake pedal. Brake lights of the light bar and towing vehicle should come "on" and "off" simultaneously with each application.
3. Turn left turn signal on. Left turn light of light bar and towing vehicle should flash simultaneously. Should the turn signal lights of the light bar function opposite to those of the towing vehicle, it is probable that the **YELLOW** and **GREEN** wires have been reversed. Check the plug connections to make sure wire colors are not crossed at any point. If plug connection is incorrect, correct problem by reversing yellow and green wire connection on the towing vehicle.

OPTIONAL 3-1/2" EXTENDED MALE RECEIVER TUBE PARTS BREAKDOWN

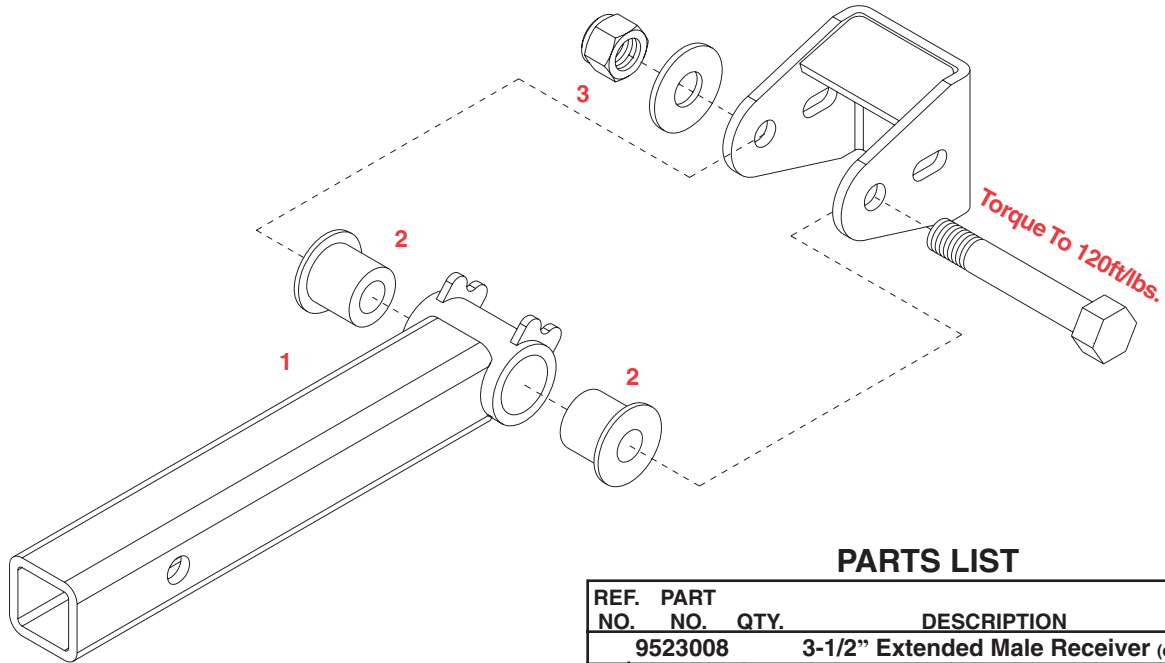

PARTS LIST

REF. NO.	PART NO.	QTY.	DESCRIPTION
	9523008		3-1/2" Extended Male Receiver (complete)
1.	07498-81	1	Extended Receiver Tube 3-1/2" with bushings
2.	03808	2	Cross Tube Bushing
3.	02961	1	3/4"-10UNC Nylon Insert Locknut

Please order replacement parts by PART NO. and DESCRIPTION.

OPTIONAL DROP/LIFT RECEIVER HITCH PARTS BREAKDOWN

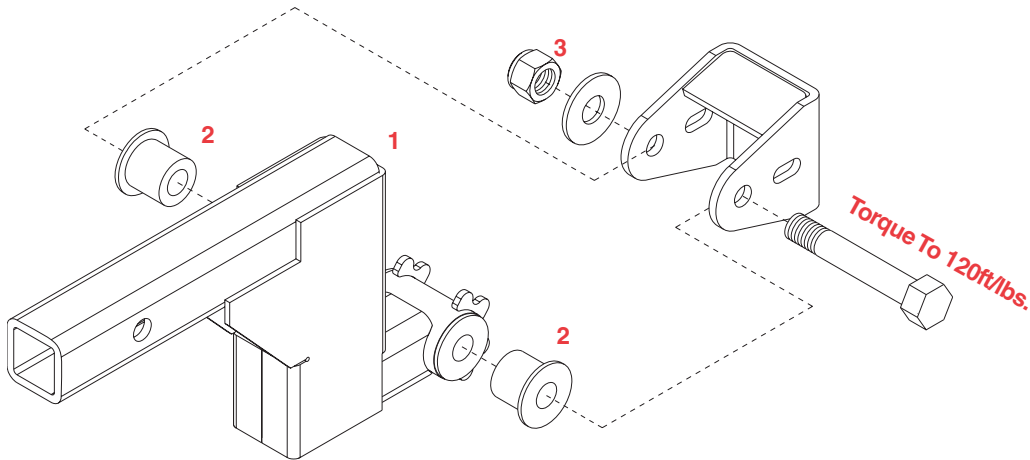

PARTS LIST

REF. NO.	PART NO.	QTY.	DESCRIPTION
	9523038		6" Drop/Lift Receiver Hitch (complete)
	9523039		3" Drop/Lift Receiver Hitch (complete)
1.	11500-81	1	6" Drop/Lift Receiver Tube (shown)with bushings
-	11501-81	1	3" Drop/Lift Receiver Tube with bushings
2.	03808	2	Cross Tube Bushing
3.	02961	1	3/4"-10 UNC Nylon Insert Locknut

Please order replacement parts by PART NO. and DESCRIPTION.

OPTIONAL TOW-BAR TO BASE PLATE LOCKING PINS

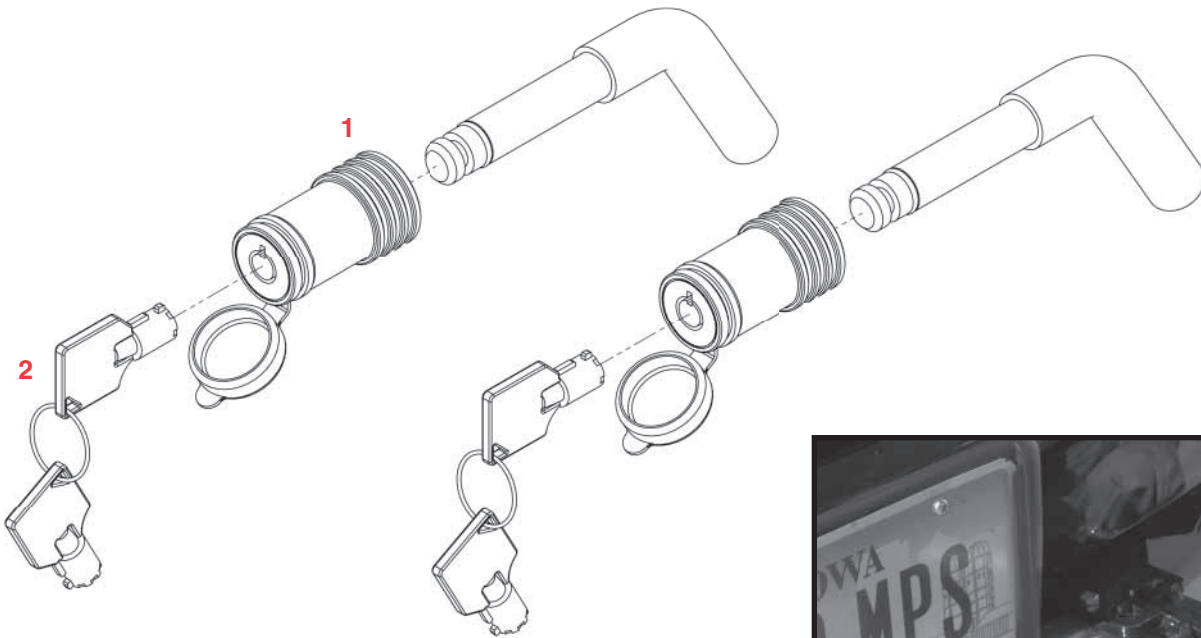

PARTS LIST

REF. NO.	PART NO.	DESCRIPTION
	9523043	Tow-Bar to Base Plate Locking Pin Set
1.	5847	Tow-Bar to Base Plate Single Locking Pin Assembly
2.	12431	Replacement Keys

Please order replacement parts by PART NO. and DESCRIPTION.



OPTIONAL 3-PIECE LOCKING PINS

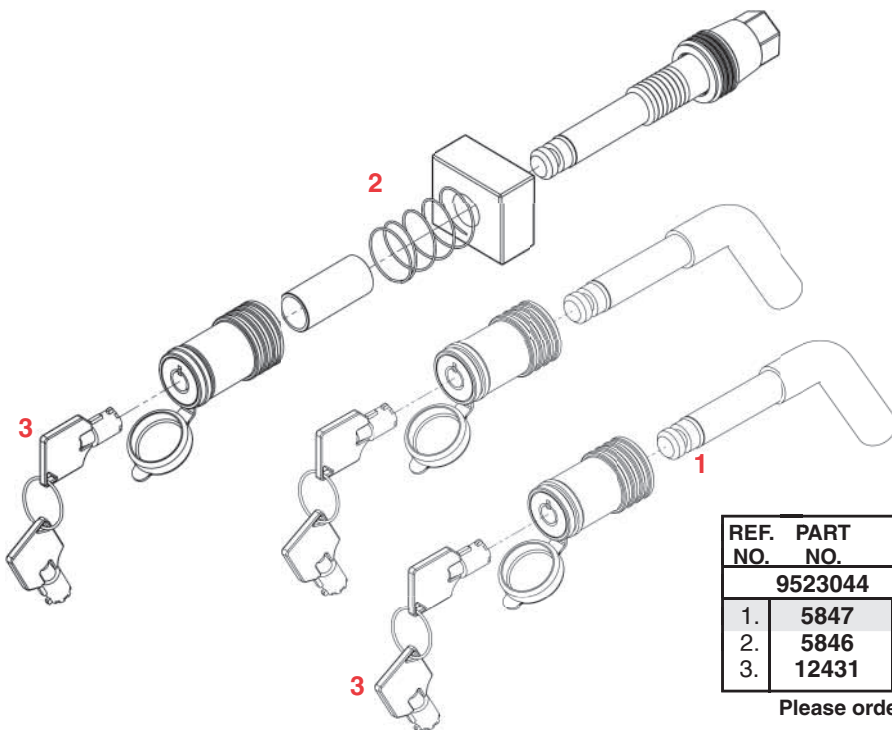

PARTS LIST

REF. NO.	PART NO.	DESCRIPTION
	9523044	3-Piece Locking Pin Set
1.	5847	Tow-Bar to Base Plate Single Locking Pin Assembly
2.	5846	Tow-Bar to Motor Home receiver Locking Pin
3.	12431	Replacement Keys

Please order replacement parts by PART NO. and DESCRIPTION.

DEMCO PRODUCTS - *Aluminator™* Tow Bar ORIGINAL PURCHASERS LIMITED WARRANTY

1. Extent and Duration of this Warranty:

Your Demco *Aluminator™* has a Lifetime Limited warranty to be free from defects in materials and workmanship under normal use and service from date of purchase by the original (first) retail owner, or until it is resold or transferred by the original owner. Any part of the Demco *Aluminator™* found in the judgement of the manufacturer to be defective in materials or workmanship will be repaired or replaced at the manufacturer's option without charge for parts or labor to the original owner.

2. Manufacturer and Warrantor of Tow Bar:

Dethmers Manufacturing Co.
4010 320th Street
P.O. Box 189
Boyden, IA 51234
(712) 725-2311

3. Repair or Replacement Procedure:

If your Demco Tow Bar develops a defect during the warranty period, promptly notify Dethmers Manufacturing Co. customer service department. Until such notice is received, Warrantor will not be responsible for any repair or replacement.

Upon receipt of notice from you, Warrantor will have a choice of options in replacing any part it determines to be defective:

- a) Warrantor may require you at your own expense to deliver or ship the part to its factory or authorized dealer. Any defective part will be repaired or replaced and returned to you free of charge. Any part returned to Warrantor and found not to be defective will be returned to you freight collect with an explanation.
- b) Warrantor may elect to ship a new part to its dealer to be exchanged free of charge for the defective part returned by you to the dealer.
- c) Warrantor may elect to ship or deliver a replacement part to your address.

4. Limitations on Warranty Coverage:

Coverage under this warranty will be valid only if the customer warranty card is returned by the original purchaser within 30 days of purchase.

Coverage under this warranty will be effective only when a copy of the original invoice, showing the date and location of purchase, accompanies any claim for warranty.

Warrantor has no liability whatsoever and this warranty is null and void if any Demco Tow Bar has been misassembled or subjected to neglect, negligence, misuse, accident or operated in any way contrary to the operating and maintenance instructions as specified in the Demco Owner's Manual for that model tow bar.

This warranty does not cover any tow bar that has been altered or modified so as to affect the tow bar's operation, performance or durability, or that has been modified to change the intended use of the tow bar.

In addition, the warranty does not extend to repairs made necessary by normal use of parts, accessories or other equipment which in the judgment of Warrantor, are either incompatible with the Demco Tow Bar, or affect its operation, performance or durability.

This warranty does not cover:

- 1) normal wear and tear
- 2) road film or gravel damage to paint
- 3) paint
- 4) rust damage
- 5) Any Demco Tow Bar that has been loaded in excess of the load capacity stated on the tow bar identification label.

Warrantor has a policy of continuous product improvement. We reserve the right to change or improve the design of any Demco Tow Bar model, including but not limited to state of the art changes, without assuming any obligation to modify any tow bar previously manufactured.

Warrantor assumes no responsibility to the owner for loss of use of the tow bar, loss of time, inconvenience or other damage consequential or otherwise, including, but not limited to expense for gasoline, expense of transporting the tow bar to the dealer and expense of returning the tow bar, mechanic's travel time, telephone or telegram charges, road service/towing charges, rental of another tow bar during the time warranty repairs are being performed, travel, lodging, loss or damage to personal property or loss of revenue or earnings.

5. Limitations of Implied Warranties:

All implied warranties, if any, expire and terminate upon expiration of this warranty. Some states do not allow limitation on how long an implied warranty lasts, so this limitation may not apply to you.

6. Limitation of Consequential Damages:

Warrantor's responsibility under this warranty extends solely to repair or replacement of your Demco Tow Bar and its component parts.

Warrantor does not assume responsibility for, nor shall it be liable for, any special, incidental or consequential damages. Some states do not allow the exclusion or limitation on incidental or consequential damages, so the above exclusion or limitation may not apply to you.

7. Use of Serial Number Identification (SN):

The SN is a 6 digit number located on the tow bar identification label. The label is located on the bottom side of the tow bar rear yoke. Be sure to include the SN number in all communications with Warrantor or its dealers concerning the warranty.

Serial No. _____

8. Purchaser's Rights:

This warranty gives you specific legal rights, and you may also have other rights which vary from state to state.

9. Exclusive Warranty:

This is the only express warranty made by Dethmers Manufacturing Co. on your Demco Tow Bar and no agent, employee, or other person is allowed to change or add to this warranty.



P.O. BOX 189
4010 320th St., BOYDEN, IA. 51234
PH: (712) 725-2311
FAX: (712) 725-2380
TOLL FREE: 1-800-54DEMCO (1-800-543-3626)
www.demco-products.com